

01 TYPICAL PARKING LANDSCAPE STRIP NOT TO SCALE

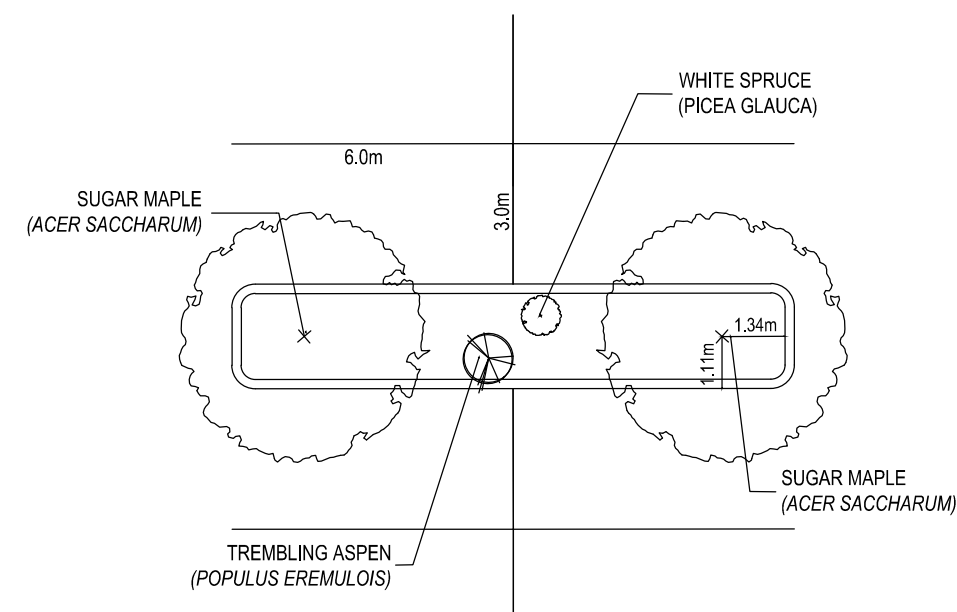

02 TYPICAL PARKING ISLAND NOT TO SCALE

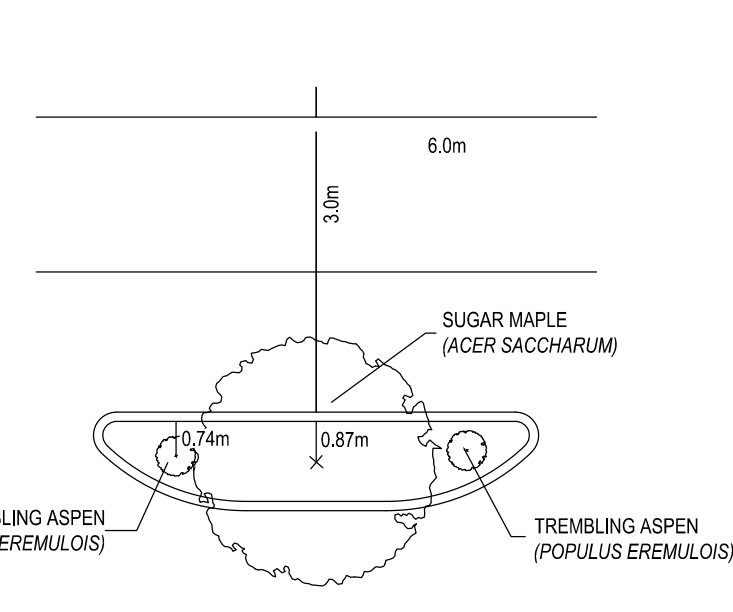

03 TYPICAL PARKING END CAP NOT TO SCALE

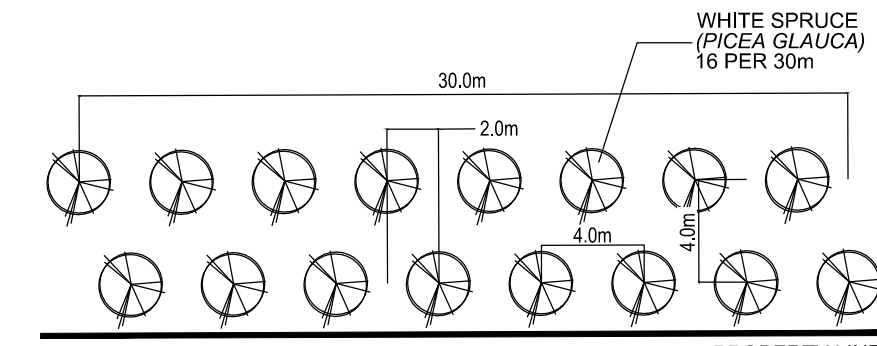

04 PROPERTY LINE PLANTINGS NOT TO SCALE

LEGAL DESCRIPTION
 PART OF LOT 26
 CONCESSION 14,
 GEOGRAPHIC TOWNSHIP OF EAST LUTHER
 TOWN OF GRAND VALLEY
 COUNTY OF DUFFERIN

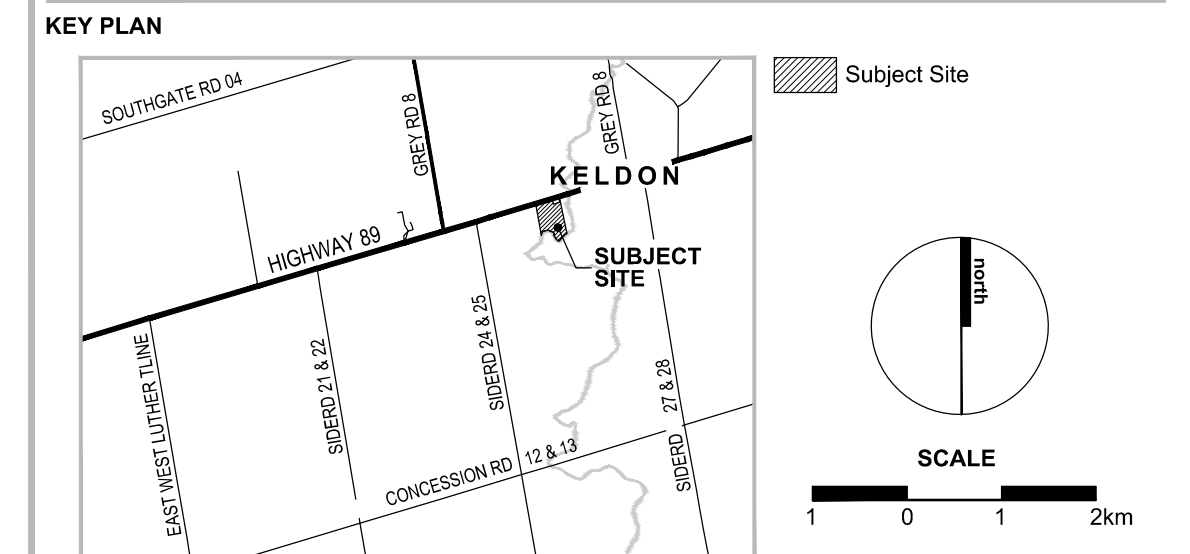

LEGEND

NOTES

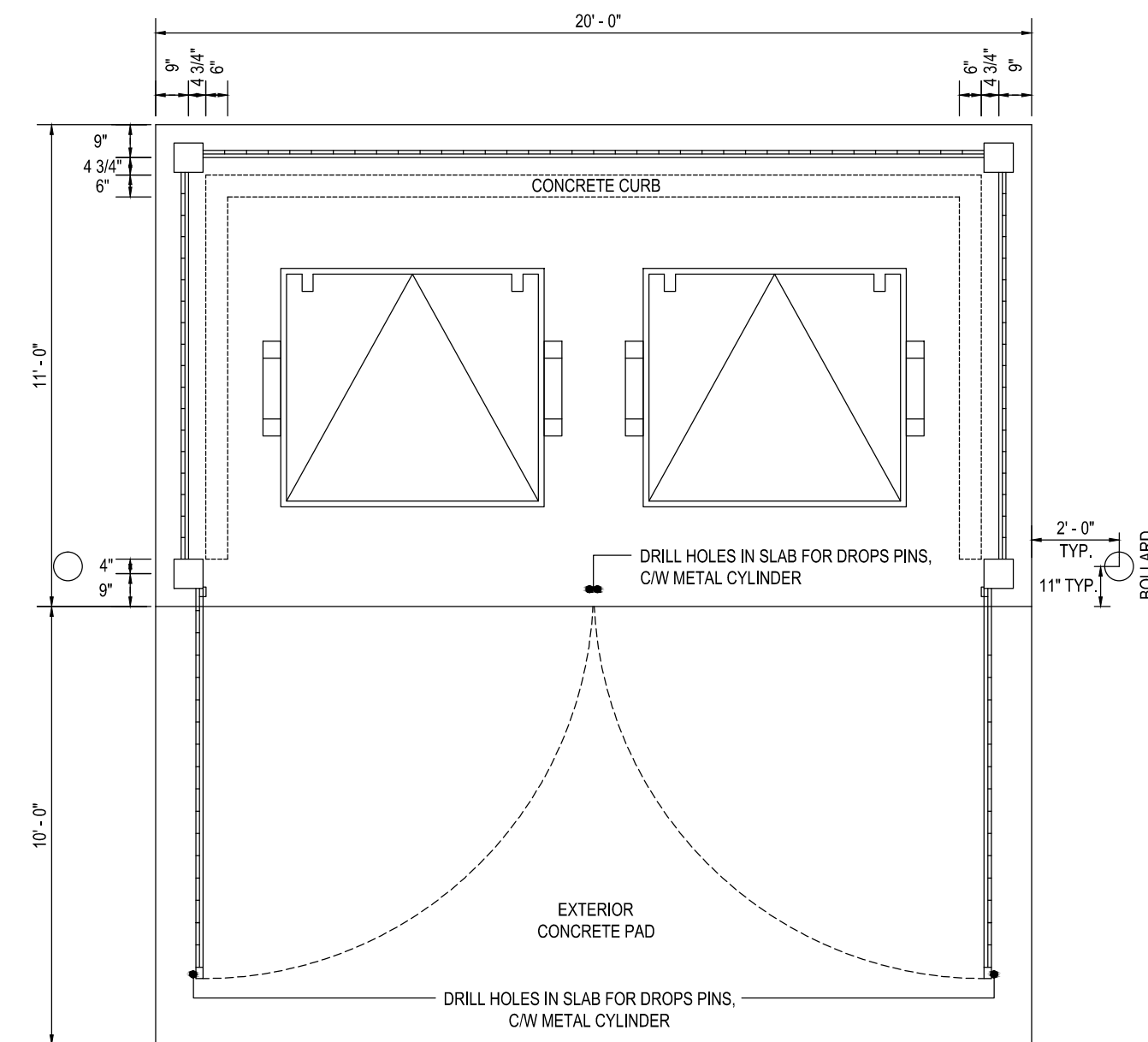

05 GARBAGE ENCLOSURE 1 OF 3 NOT TO SCALE

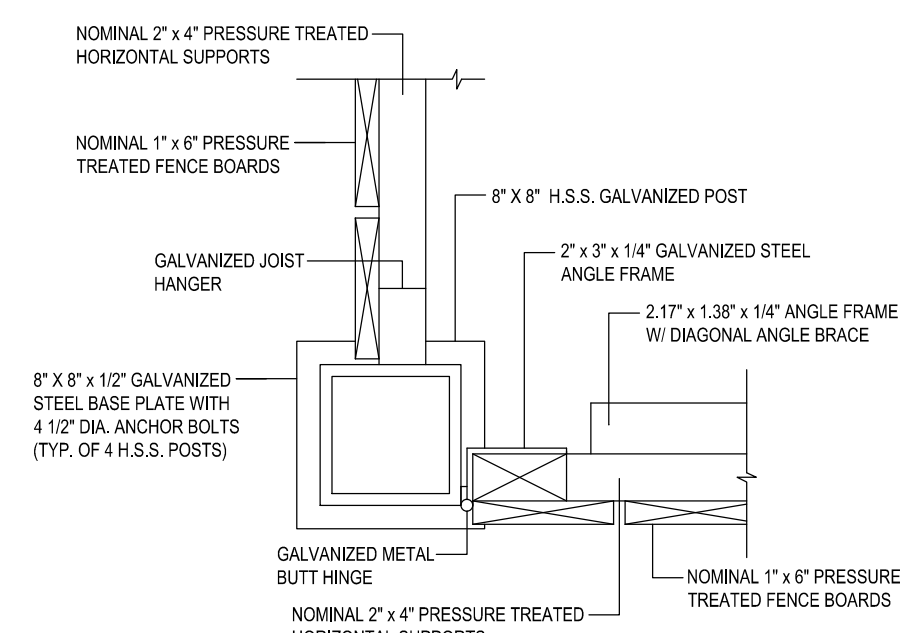

06 GARBAGE ENCLOSURE 2 OF 3 NOT TO SCALE

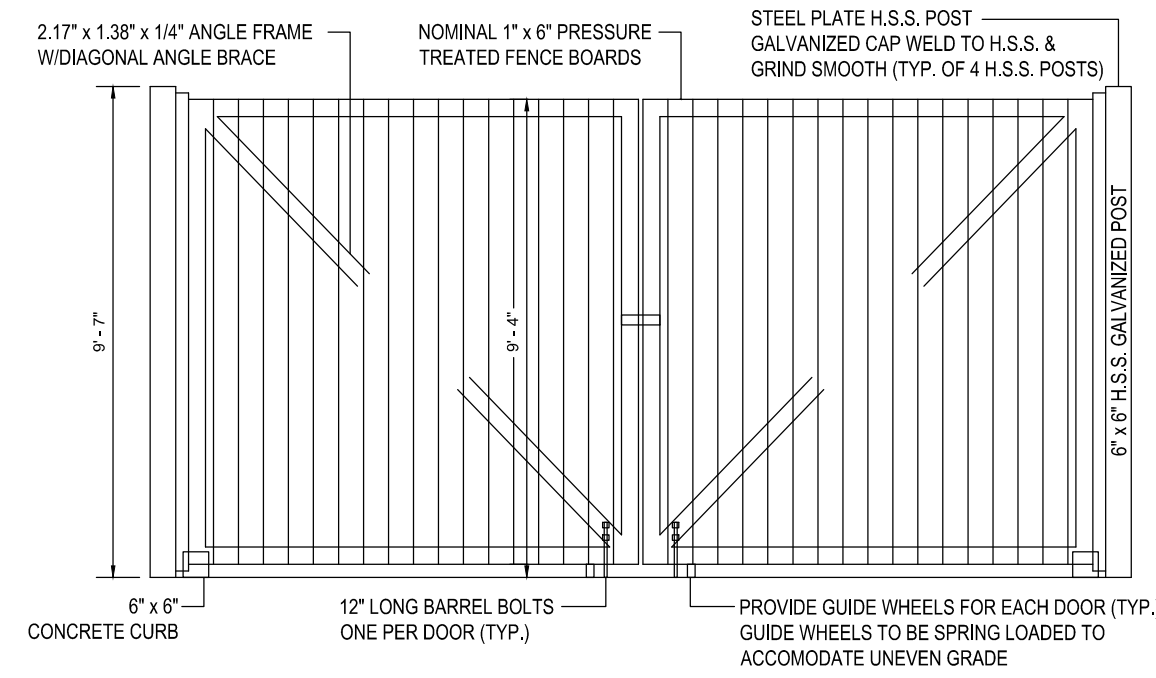

07 GARBAGE ENCLOSURE ELEVATION 3 OF 3 NOT TO SCALE

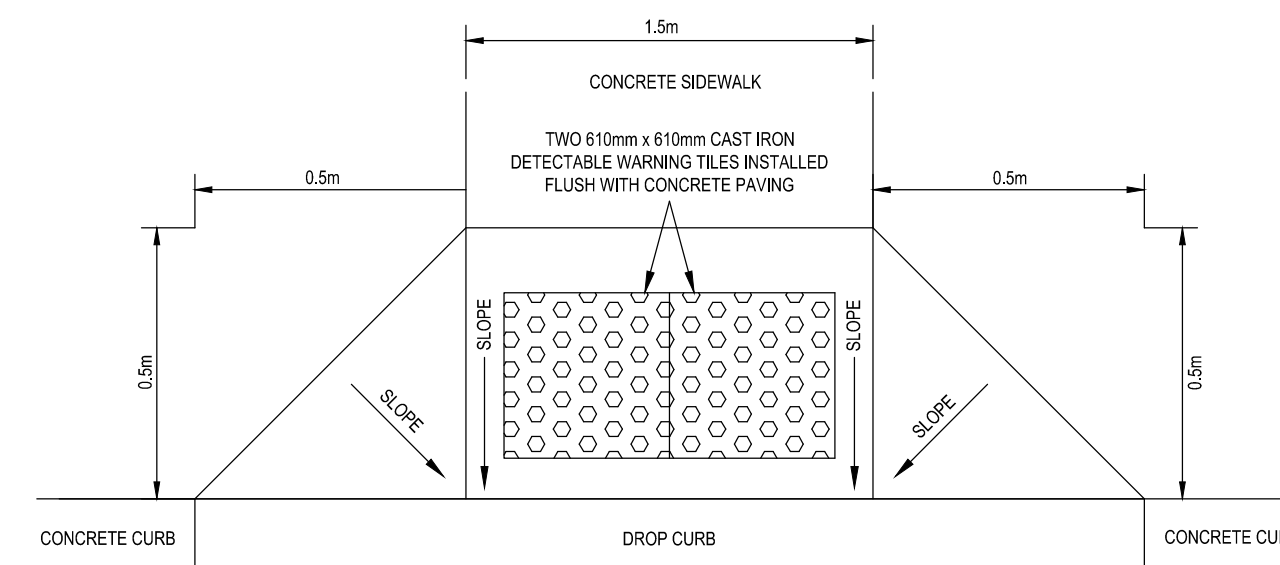

08 CURB RAMP WITH DETECTABLE WARNING TILES NOT TO SCALE

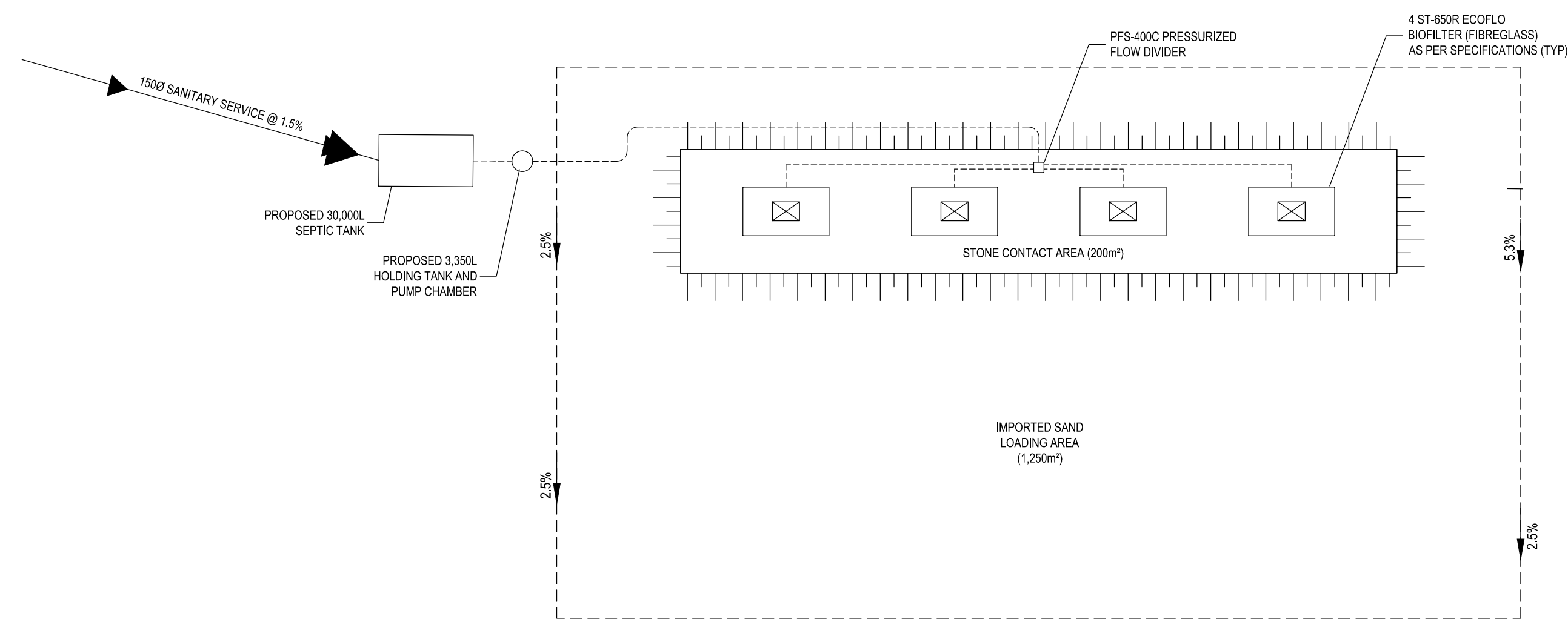

09 SEPTIC SYSTEM NOT TO SCALE

REVISION No. DATE ISSUED/REVISION BY

PLANNING URBAN DESIGN & LANDSCAPE ARCHITECTURE
 MHBC PLANNING
 113 COLLIER STREET
 BARRIE, ON, L4M 1H2
 P: 705 728 0045 F: 705 728 2010
 WWW.MHBCPLAN.COM

STAMP	DATE	October 25, 2017
	DRAWN BY	M.A.M.
	PLAN SCALE	N.T.S. (ARCH D)
	FILE No.	16186A
	CHECKED BY	J.D.
	OTHER	

PROJECT
 502080 HIGHWAY 89
 CANWE GROWERS INC.

FILE NAME DETAILS DWG No. 2 of 2

SCALE NOT TO SCALE